



## 4-INPUT OR/NOR

**SY10EL01**  
**SY100EL01**

### FEATURES

- 230ps propagation delay
- High bandwidth output transitions
- Internal 75K $\Omega$  input pull-down resistors
- Available in 8-pin SOIC package

### DESCRIPTION

The SY10/100EL01 are 4-input OR/NOR gates. These devices are functionally equivalent to the E101 devices, with higher performance capabilities. With propagation delays and output transition times significantly faster than the E101, the EL01 is ideally suited for those applications which require the ultimate in AC performance.

### PIN NAMES

Pin	Function
D <sub>0</sub> -D <sub>3</sub>	Data Inputs
Q	Data Outputs

**PACKAGE/ORDERING INFORMATION**

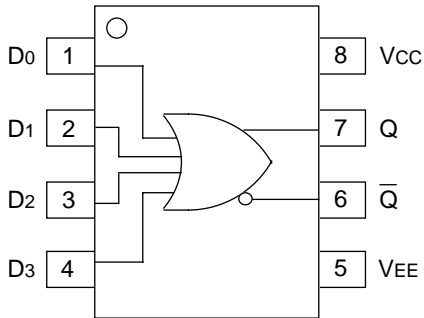

**8-Pin SOIC (Z8-1)**

**Ordering Information<sup>(1)</sup>**

Part Number	Package Type	Operating Range	Package Marking	Lead Finish
SY10EL01ZC	Z8-1	Commercial	HEL01	Sn-Pb
SY10EL01ZCTR <sup>(2)</sup>	Z8-1	Commercial	HEL01	Sn-Pb
SY100EL01ZC	Z8-1	Commercial	XEL01	Sn-Pb
SY100EL01ZCTR <sup>(2)</sup>	Z8-1	Commercial	XEL01	Sn-Pb
SY10EL01ZI	Z8-1	Industrial	HEL01	Sn-Pb
SY10EL01ZITR <sup>(2)</sup>	Z8-1	Industrial	HEL01	Sn-Pb
SY100EL01ZI	Z8-1	Industrial	XEL01	Sn-Pb
SY100EL01ZITR <sup>(2)</sup>	Z8-1	Industrial	XEL01	Sn-Pb
SY10EL01ZG <sup>(3)</sup>	Z8-1	Industrial	HEL01 with Pb-Free bar-line indicator	Pb-Free NiPdAu
SY10EL01ZGTR <sup>(2, 3)</sup>	Z8-1	Industrial	HEL01 with Pb-Free bar-line indicator	Pb-Free NiPdAu
SY100EL01ZG <sup>(3)</sup>	Z8-1	Industrial	XEL01 with Pb-Free bar-line indicator	Pb-Free NiPdAu
SY100EL01ZGTR <sup>(2, 3)</sup>	Z8-1	Industrial	XEL01 with Pb-Free bar-line indicator	Pb-Free NiPdAu

**Notes:**

1. Contact factory for die availability. Dice are guaranteed at T<sub>A</sub> = 25°C, DC Electricals only.
2. Tape and Reel.
3. Pb-Free package is recommended for new designs.

**DC ELECTRICAL CHARACTERISTICS**V<sub>EE</sub> = V<sub>EE</sub> (Min.) to V<sub>EE</sub> (Max.); V<sub>CC</sub> = GND

Symbol	Parameter	T <sub>A</sub> = -40°C			T <sub>A</sub> = 0°C			T <sub>A</sub> = +25°C			T <sub>A</sub> = +85°C			Unit
		Min.	Typ.	Max.	Min.	Typ.	Max.	Min.	Typ.	Max.	Min.	Typ.	Max.	
I <sub>EE</sub>	Power Supply Current													mA
	10EL	—	14	17	11	14	17	11	14	17	11	14	17	
	100EL	—	14	17	11	14	17	11	14	17	13	16	20	
V <sub>EE</sub>	Power Supply Voltage													V
	10EL	-4.75	-5.2	-5.5	-4.75	-5.2	-5.5	-4.75	-5.2	-5.5	-4.75	-5.2	-5.5	
	100EL	-4.20	-4.5	-5.5	-4.20	-4.5	-5.5	-4.20	-4.5	-5.5	-4.20	-4.5	-5.5	
I <sub>IH</sub>	Input HIGH Current	—	—	150	—	—	150	—	—	150	—	—	150	μA

**AC ELECTRICAL CHARACTERISTICS**V<sub>EE</sub> = V<sub>EE</sub> (Min.) to V<sub>EE</sub> (Max.); V<sub>CC</sub> = GND

Symbol	Parameter	T <sub>A</sub> = -40°C			T <sub>A</sub> = 0°C			T <sub>A</sub> = +25°C			T <sub>A</sub> = +85°C			Unit
		Min.	Typ.	Max.	Min.	Typ.	Max.	Min.	Typ.	Max.	Min.	Typ.	Max.	
t <sub>PD</sub>	Propagation Delay to Output D	70	220	370	120	220	320	130	230	330	150	250	350	ps
t <sub>r</sub> t <sub>f</sub>	Output Rise/Fall Times Q (20% to 80%)	70	225	350	100	225	350	100	225	350	100	225	350	ps

**8-PIN SOIC .150" WIDE (Z8-1)**

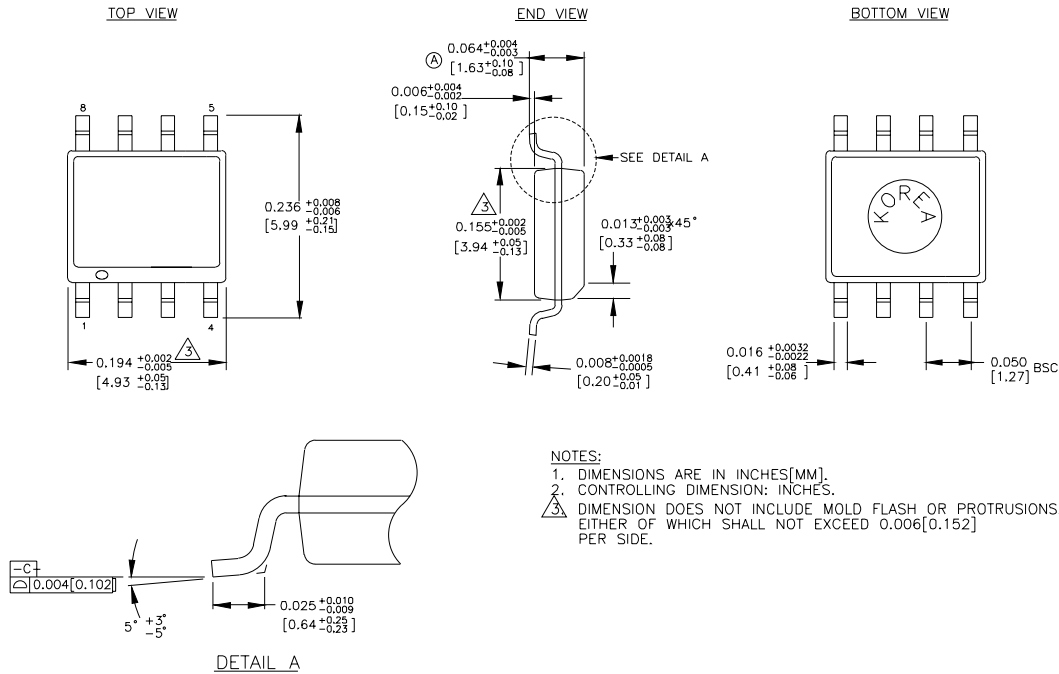

Rev. 03

**MICREL, INC. 2180 FORTUNE DRIVE SAN JOSE, CA 95131 USA**

TEL + 1 (408) 944-0800 FAX + 1 (408) 474-1000 WEB <http://www.micrel.com>

The information furnished by Micrel in this datasheet is believed to be accurate and reliable. However, no responsibility is assumed by Micrel for its use. Micrel reserves the right to change circuitry and specifications at any time without notification to the customer.

Micrel Products are not designed or authorized for use as components in life support appliances, devices or systems where malfunction of a product can reasonably be expected to result in personal injury. Life support devices or systems are devices or systems that (a) are intended for surgical implant into the body or (b) support or sustain life, and whose failure to perform can be reasonably expected to result in a significant injury to the user. A Purchaser's use or sale of Micrel Products for use in life support appliances, devices or systems is at Purchaser's own risk and Purchaser agrees to fully indemnify Micrel for any damages resulting from such use or sale.

© 2006 Micrel, Incorporated.